



NK Technologies



A P P L I C A T I O N G U I D E



Motors **1**

- Pump Jam & Suction Loss Protection 1
- Fan Status: Independant Verification of Operation 2
- Conveyor Jam Protection 2
- Pump Load Monitoring 3
- Crusher/Grinder/Shredder Motor Interlocks 4
- Saw Load Monitoring 5
- Moisture Ingress on a Submersible Pump Motor 5
- DC Motor Installations 6
- Vacuum Pump Monitor 6
- Status Alarming 7
- Spin Pumps 7
- Closed Loop Control 8

Heaters **9**

- Heater Failure Detection 9
- Heater Life Prediction 10
- Insulation Breakdown 10
- Ground Fault Monitoring on Heat Trace Systems 11
- Snow Melt Systems 12

Industrial Lighting **13**

- Lamp failure Detection 13
- Preventative Maintenance of a Critical Lighting System 14
- UV & IR Lamp Status Monitoring 14

Miscellaneous **15**

- Isolated Alarm System Interfacing 15
- Battery Charging system 15
- Solar Panels 17
- Current Transformer Monitoring 17
- Equipment Ground Fault Monitoring 18
- Generator Installations 19
- Power Transformer Monitoring 19
- Power Factor Correction Control 20
- Welder Tip Dressing 21
- Safety Interlocks 21
- Drill/Tool Status 22

Industry	Pages
Aggregates/Cement	1, 2, 3, 5, 6, 7, 8, 9, 17, 19, 20
Agriculture & Aquaculture	1, 2, 3, 5, 7, 8, 10, 18
Biotech & Biopharm	1, 2, 3, 5, 6, 7, 8, 9, 14, 15, 18
Chemicals	1, 2, 5, 6, 7, 8, 9, 10, 11, 12, 13, 14, 15, 17, 18, 19, 20, 21
Extrusion	1, 2, 6, 7, 8, 9, 10, 11, 14, 18, 20
Food & Beverage, Bottling & Canning	1, 2, 3, 6, 7, 8, 9, 10, 18
Fountains	1, 2, 6, 7, 14, 18, 19
Furnaces & Kilns	2, 6, 9, 10, 14, 18, 21
Generators	19, 20
Machine Tools	6, 18, 21, 22
Manufacturing	3, 8, 11, 18, 20, 21, 22
Material Handling & Conveyors	2, 6
Material Reduction – Shredders & Grinders	2, 4, 5, 18, 20
Metals	2, 4, 6, 7, 9, 10, 17, 18, 19, 20, 21, 22
Mining	1, 2, 3, 4, 5, 6, 7, 8, 13, 15, 17, 18, 19, 20, 21, 22
Oil & Gas	1, 2, 3, 5, 6, 7, 8, 9, 10, 11, 13, 15, 17, 18, 19, 20, 21, 22
Pharmaceuticals	1, 2, 3, 4, 5, 6, 7, 8, 9, 14, 15, 18
Petrochemicals	1, 2, 3, 5, 6, 7, 8, 9, 10, 11, 13, 15, 17, 18, 19, 20, 21, 22
Plastics & Rubber	4, 6, 9, 10, 18
Pumps & Irrigation	1, 2, 4, 7, 18
Refrigeration & Compressors	1, 2, 18
Semiconductor Manufacture	9, 10, 15, 18, 19
Snow Melt	12, 13
Solar	17, 18
Test Cells/Stands	3, 6, 10, 15, 17, 21
Textiles	1, 2, 6, 7, 8, 9, 10, 14
Timber & Logging	5, 6, 18, 21, 22
Utilities and Power Generation	1, 2, 3, 5, 6, 7, 8, 11, 12, 13, 14, 15, 17, 18, 19, 20, 21
Water & Wastewater	1, 2, 3, 5, 6, 7, 8, 11, 12, 13, 14, 15, 17, 18, 19, 20, 21
Welding	17, 19, 21

Motors

Electric motors are found extensively in both the manufacturing and processing industries. Both AC and DC powered motors are used to drive pumps, fans, conveyors and a broad range of specialized equipment. There are many types of motors designed for many different applications, however all require electrical current in order to generate the magnetic fields that are necessary to create rotation. By measuring this current useful information can be made available regarding the status of the motor and the equipment that is connected to it. This may be as basic as independently verifying the run status of the motor or in conjunction with a PLC, for example, to protect a pump against dry run. Thus current may be used to both monitor and protect motors and motor-driven equipment.

Following is just a sample of some of the extensive applications that NK Technologies' Industrial Current sensors are used together with electric motors:

Pump Jam & Suction Loss Protection

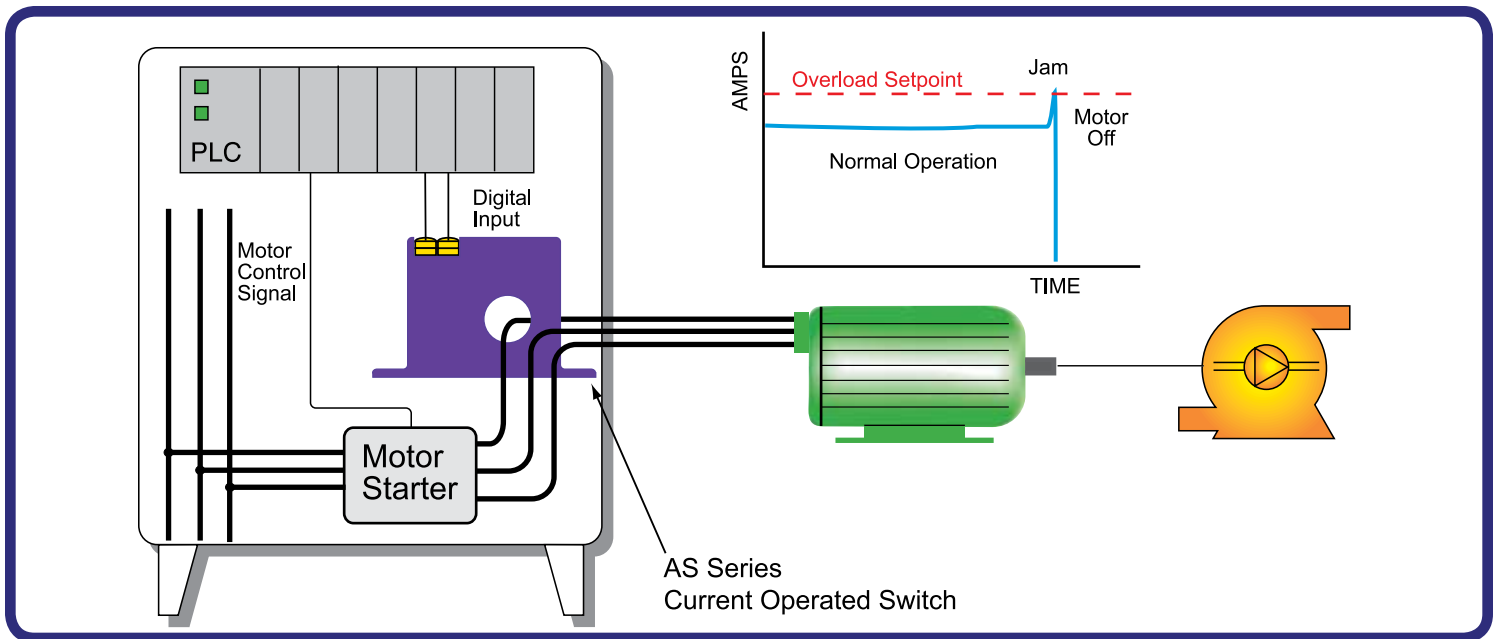

Pumps can become jammed due to foreign matter and cause damage to both the pump and the motor before thermal overloads are tripped. Additionally a blockage in the suction line of the pump can cause the pump to run dry, overheat and break a seal.

By simply installing an NK Technologies' self-powered **Current Operated Switch** in one leg of the motor overload (pump jam), underload (suction loss) or underload & overload can be detected quickly before damage occurs

Fan Status: Independent Verification of Operation



Good engineering practice suggests that every control output should have a corresponding status input for verification. On fans and pumps a current operated switch can be snapped over one motor leg and the output fed to the automation system. NK Technologies' self-powered **Current Operated Switches** will close when the motor turns on and open when the motor is off. By adjusting the setpoint pump coupling or fan belt failure can be detected. This reliable solid-state solution eliminates the need for unreliable pressure current switches and their costly installation.

Conveyor Jam Protection

When conveyors jam and the drive motor continues to run, expensive mechanical damage to the drive components often occurs. By installing an NK Technologies' **Current Operated Switch** an overload condition, detected by higher than normal running amps, can be used to switch off power to the motor before mechanical damage results. The switch setting can be adjusted so it is not affected by normal changes in conveyor load. Current operated switches are the modern day equivalent of less reliable electromechanical jam relays that have been in use for many decades.

In situations where there may be large variations in load an NK Technologies' **Current Transducer** may be used to feed motor amps to the conveyor control system, commonly a PLC. The PLC may be programmed to accommodate different setpoints for different

mechanical loads so that jam protection is provided from light to heavy loads. In situations where the conveyor is not able to accept analog signals NK Technologies has developed a patented transducer with a frequency output suitable for the Digital Inputs of most PLCs



Pump Load Monitoring

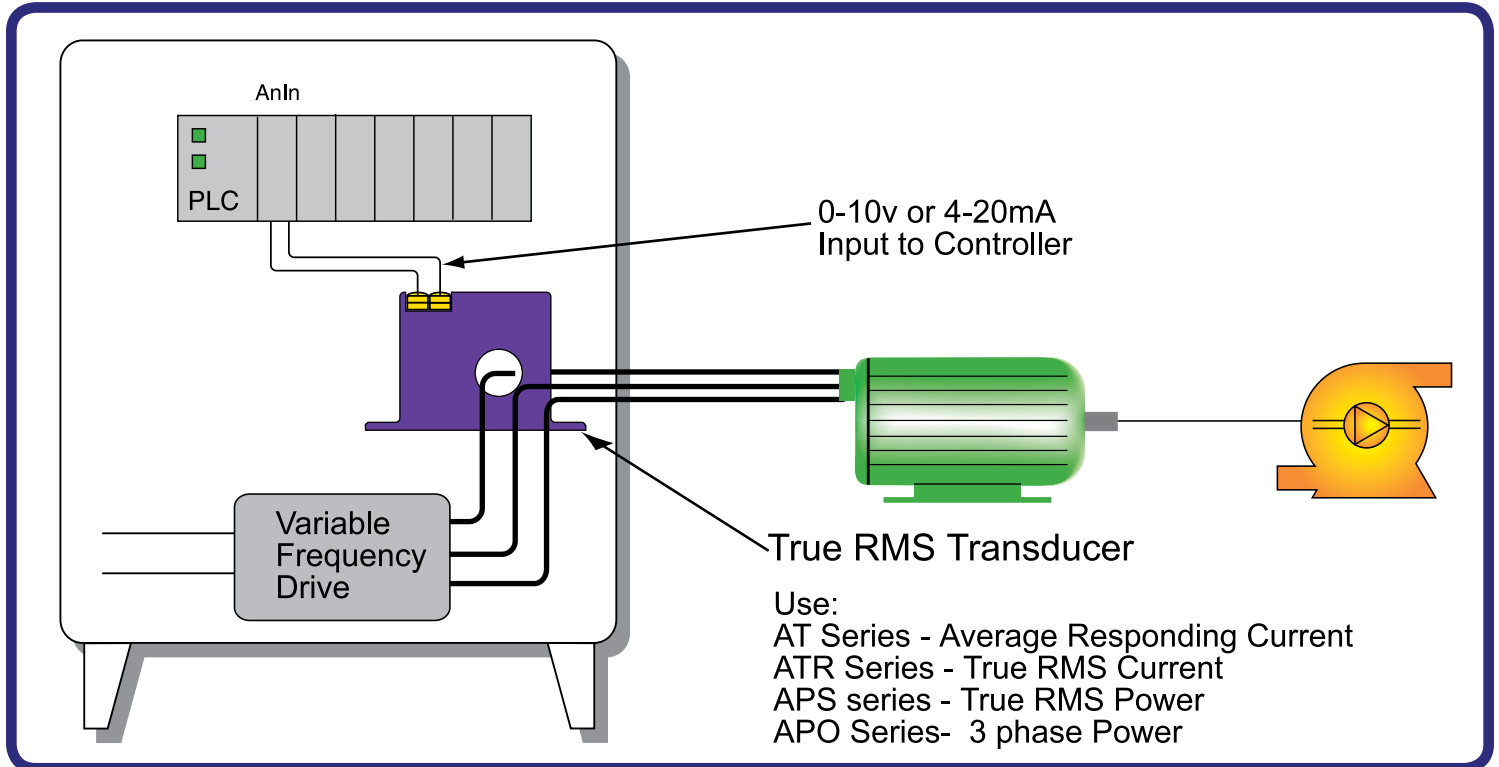

NK Technologies' **Current Transducers** are used to monitor motor current and therefore motor load. The output from the transducer may be fed to an analog or digital indicator or a Programmable Logic Controller (PLC) for more sophisticated monitoring and control.

NK Technologies' **Power Transducers** provide load monitoring in more critical applications where the addition of voltage measurement and the determination of the phase relationship between current and voltage (power factor) provides more control.

NK Technologies' **Ground Fault Sensors** keep the pumps safe by measuring ground leakage currents as low as 5mA. This also provides an alternative to moisture sensors used with submersible pump motors.

See Also: *Pump Jam & Suction Loss Protection – page 1*
Moisture Ingress on a Submersible Pump Motor – page 5

Crusher/Grinder/Shredder Motor Interlocks

The performance of size reduction equipment like crushers or grinders can be optimized by controlling the in-feed in order to

- Help prevent jamming
- Improve the uniformity of the resultant product
- Enhance overall production efficiency

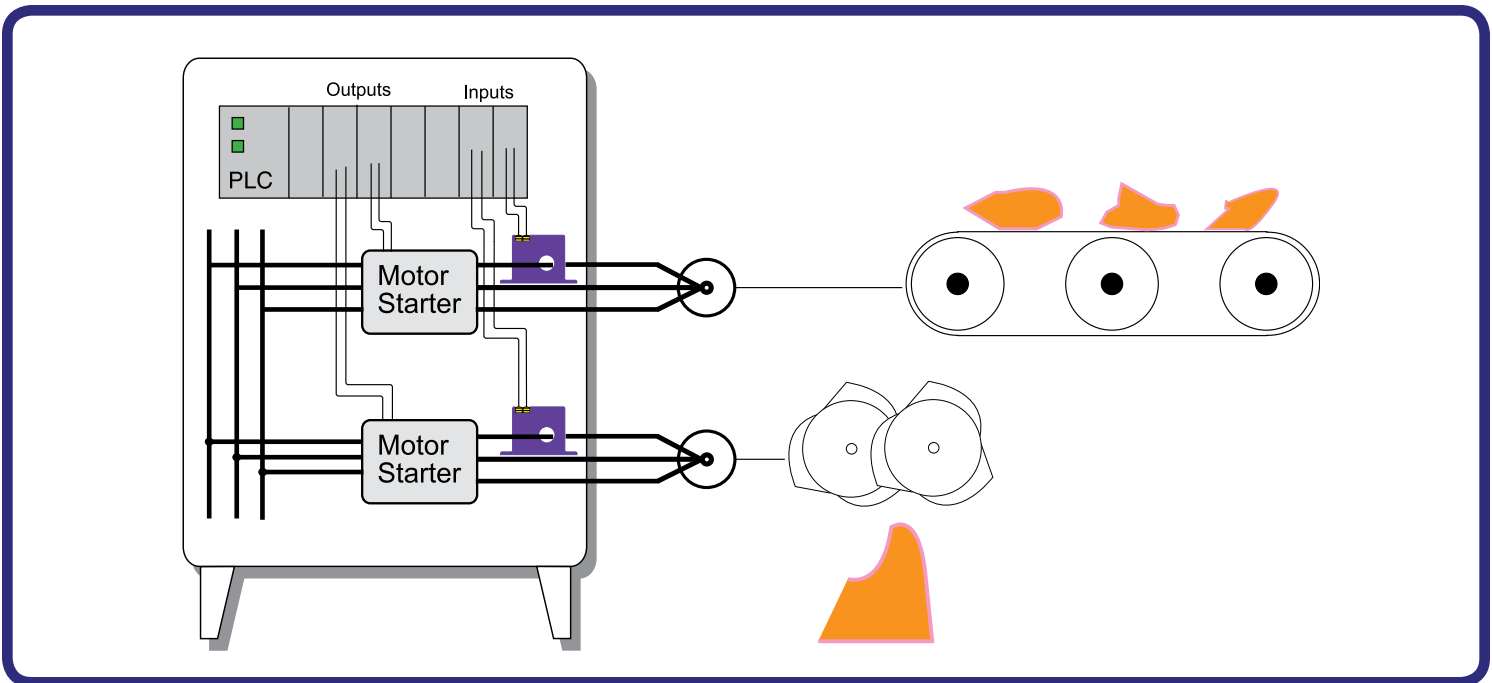

By installing an NK Technologies' **Current Transducer** or **Power Transducer** to monitor the in-feed to a crushing process, the speed of the in feed drive can be slowed when the crushing motor is working too hard, or the speed can be increased when the crusher is under worked. The analog 4-20 mA proportional signal is fed directly into a VFD, and the drive does the rest of the control.

Additionally, NK Technologies' **Current Operated Switches** installed on other conveying motors can be used to signal malfunction (for example over-load or motor failure) to help prevent costly equipment damage.

NK technologies current sensors come in a variety of configurations for quick and simple installation either for the OEM or End-User.

Saw Load Monitoring

Often a band saw is used to cut logs into rough planks, before the planks are processed into finished lumber. Due to inconsistencies in the log (knots, burls and checks), the speed that the log is pulled through the saw must be varied. The operator will often reduce the speed of the cut when smoking occurs, or the blade breaks. By installing an NK Technologies' **Current Transducer** the operator's job is made easier. By watching the log and a display representing the current draw of the band saw, the operator can achieve a higher rate of output with less down-time.



A similar arrangement can be used with circular saws. The blades become brittle after excessive heating if they are worked too hard. Many automatic systems are in use whereby the current draw is used to reduce the motor load typically by reducing the feed-rate.

Moisture Ingress on a Submersible Pump Motor

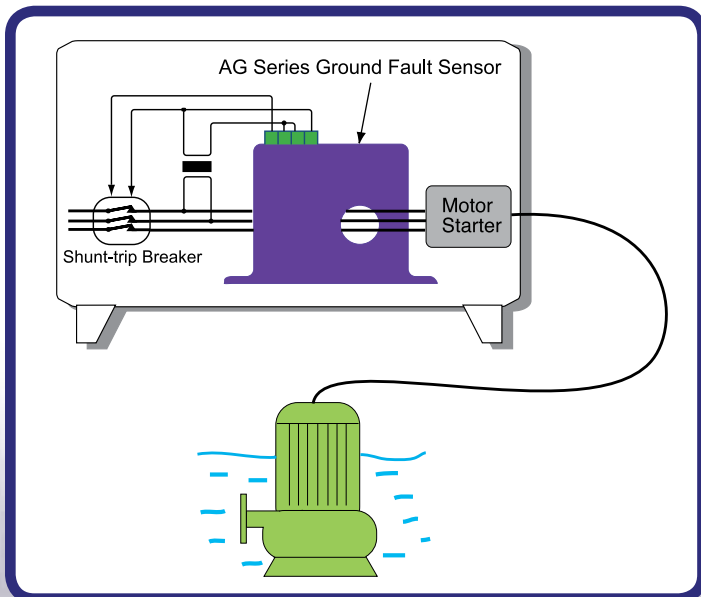

An NK Technologies' **Ground Fault Sensor** installed on a submersible pump motor provides an easy to install replacement or addition to moisture sensors housed in the motor casing. Unlike moisture sensors that have to be wired back to the motor control center, the GF sensor is installed in the motor control center. By detecting the ground fault current resulting from moisture ingress or other potentially dangerous condition remedial action can be taken prior to catastrophic failure. Either the pump can be replaced at the next convenient time or switched off and a back-up pump started.

DC Motor Installations



Many applications requiring high torque at low speeds, like bridge cranes and log carriages, use DC shunt wound motors. Since it is relatively easy to control the speed of a DC motor by adjusting the voltage to the field windings, precise regulation is afforded to applications like printing press paper feeds or web control of multiple motors in the paper making process. Using an NK Technologies' **DC Current Transducer** will provide an analog signal that can be used to keep the motor from over-current situations. Using an NK Technologies' **DC Current Operated Switch** will insure that if the motor field supply is lost, the motor will not over-speed to the point of self-destruction.

Vacuum Pump Monitor

Vacuum pumps are used in a variety of applications in the semiconductor industry, heat treatment, plastics and packaging industries. By adding an NK Technologies' **Current Transducer** over the lead feeding a vacuum pump, it can easily be determined when all the air has been removed from a vessel or envelope. The analog output can signal the vacuum or equipment controller that it is time for the next step in the process. In the case of an automated packaging machine, a drop in current will signal that the package is ready for sealing.

Motors

Status Alarming

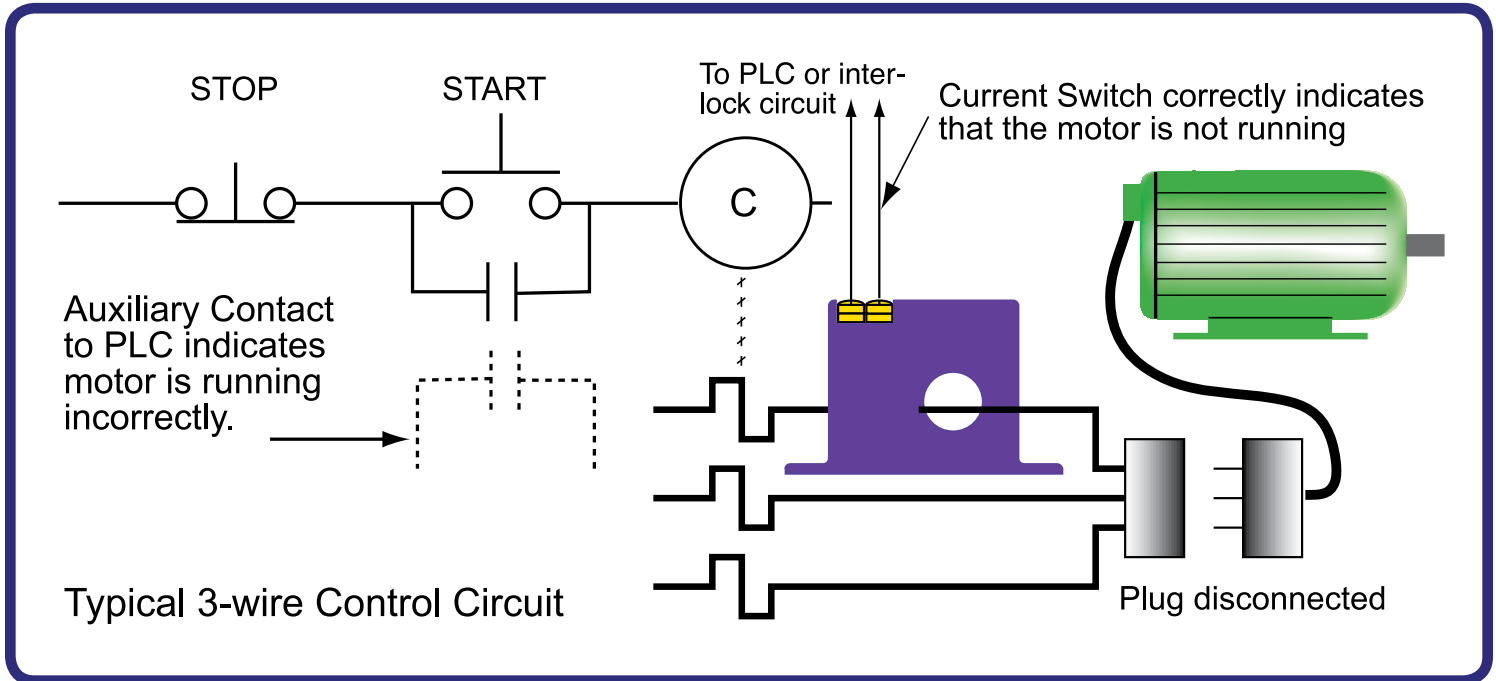

The auxiliary contacts in a motor starter are commonly used to indicate when the motor is running. However, auxiliary contacts only indicate the position of the contactor, not the actual load status. If a downstream disconnect is open (for example, for maintenance) or the contact fails (either sticks or dirt build-up) there can be serious consequences.

At a large fish farm, failed aerator pumps resulted in massive stock losses. Because the auxiliary contacts remained closed when the pump failed, the alarm was never activated, the back-up pumps were not switched on and the fish suffocated due to lack of oxygen. Now NK Technologies' **Current Operated Switches** have been installed to provide an alarm signal and a signal to automatically switch over to the back-up aerator pumps.

Spin Pumps

Spin Pumps are used in the manufacture of synthetic fibers and yarns. Very precise control is required to insure that the product feed rate and the fiber draw rate is matched. It is critical to monitor and protect these spin pumps because they are the heart of the system and are required to run continuously. By installing an NK Technologies' **Current Transducers**, the motor current may be monitored providing the control system with key information regarding load. Variations

in load may be attributable to a number of factors such as bearing failure, seal failure, suction loss etc. The measurement of load together with other process variables like pressure and flow can provide invaluable information regarding the operation of the vital spin pumps.

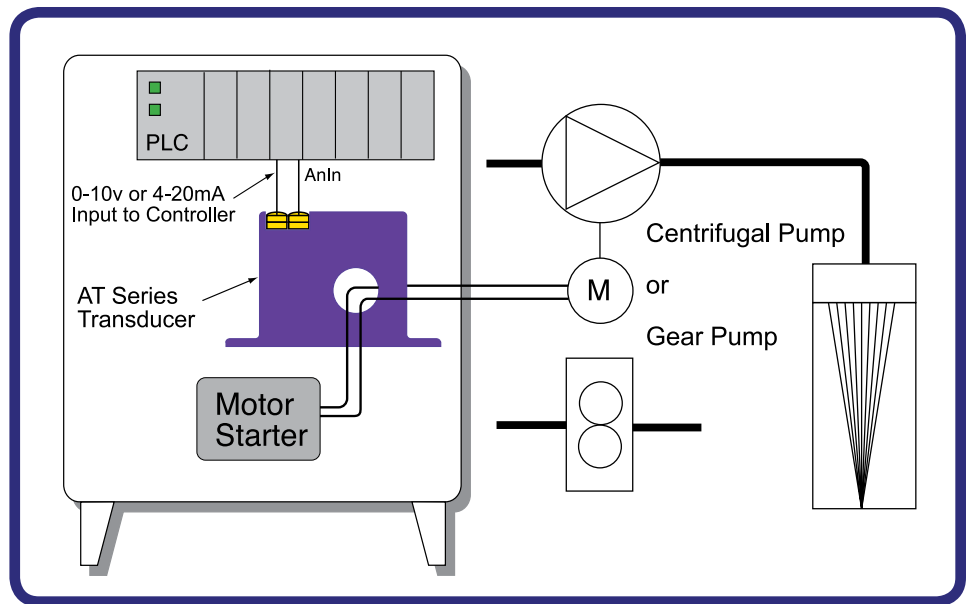

Closed Loop Control

Normal linear AC induction motors have a current characteristic that increases with load. Thus a measurement of current is proportional to the motor load. NK Technologies' **True RMS Current Transducers** (ATR Series) are designed to work in conjunction with variable frequency drives (VFD) and measure the current in the leg of the motor.

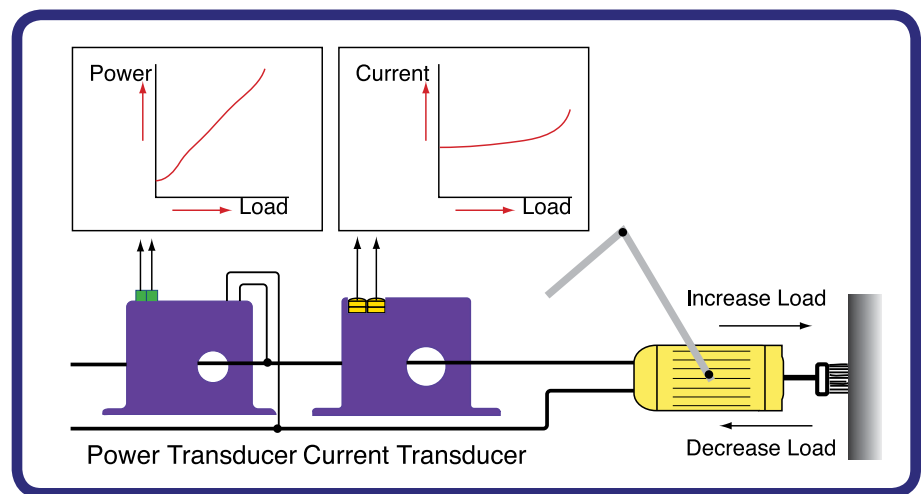

At an engine block manufacturing facility NK Technologies' **Current Transducers** (AT Series) provide the input to a PLC used to position the rotating wire brushes in order to clean away burrs and debris after machining. As the current, and thus the load, changes so the brushes are positioned for optimal clean-up. Similarly **Power Transducers** (APS Series) are used to control the position of wheel wash brushes in a carwash. Power measurement provides a more linear relationship for motors and other loads with non-linear current characteristics. **Current Operated Switches** (AS1/3 Series) are used to co-ordinate operations between conveyor, washing and drying systems.

Heaters

Electric heaters are used in a broad variety of industrial applications. Many chemical reactions require the addition of heat. Trace heating may be used to prevent process pipes from freezing or melt snow on roofs or car parks. Many plastic parts are manufactured using the addition of heat to mold them to the required form. The heat output of an electric heater is directly proportional to the square of the current flowing through it. Therefore measurement of current is useful for both process monitoring and heater status. If a heater fails, poor quality products or scrap material may be produced.

NK Technologies' Industrial Current Sensors are used in many heater applications including:

Heater Failure Detection

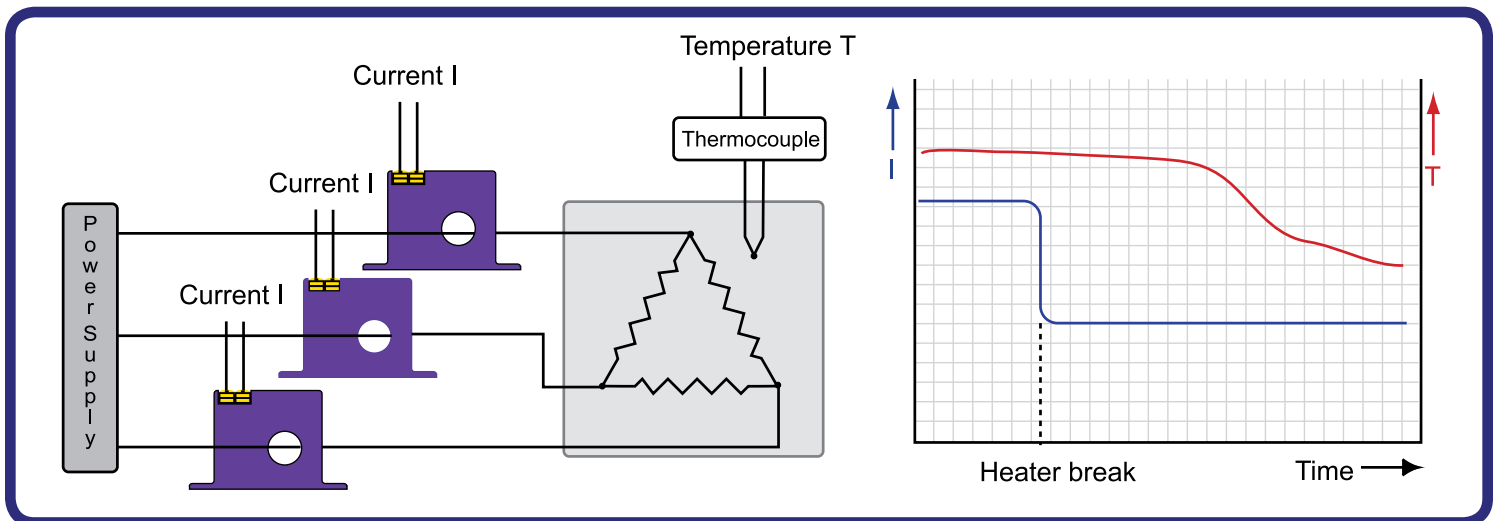

The detection of a single phase heater failure by measuring the temperature is like measuring the effect rather than the cause. By installing an NK Technologies' **Current Operated Switch** heater failure can be detected before cooling has had time to occur. The signal from the current sensor can be used to switch on a back-up heater, stop the equipment, alarm the equipment operator or trigger the appropriate action.

For 3-phase heaters installing an NK Technologies' **Current Transducer** on each leg of a delta connected heating array is the best way to detect loss of one element. Unlike a typical induction motor, there will not be a substantial change in the current draw of the two adjacent phases when a heating element open circuits. The load has disappeared, and the work of heating will not be shared by the other elements. There will be a reduction in thermal output, which can take quite some time to detect with temperature sensors like thermocouples. A current transducer will identify the problem in milliseconds! Poor product quality can be prevented and large quantities of raw material can be saved by quick action.

Heater Life Prediction

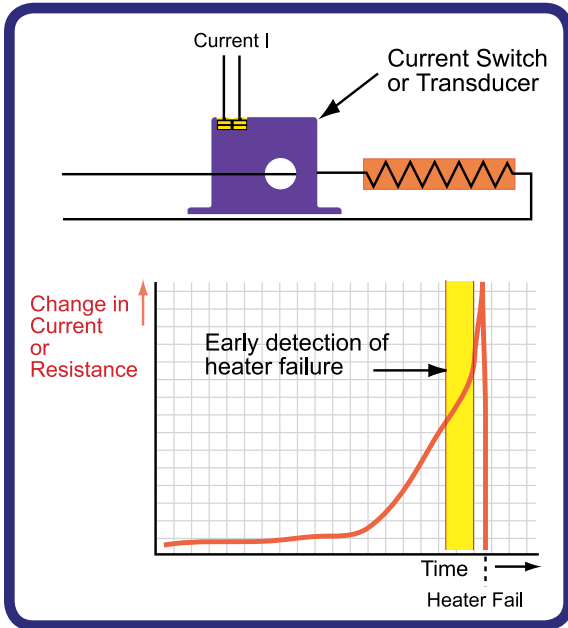

As an electric heating element ages, its resistance also changes. Many high technology and extreme temperature applications employ exotic and expensive elements. Where the value of the products or materials being heated is high, the failure of a heater or heating element has a financial impact resulting from either reduced quality or scrapped materials. By measuring the current drawn by the element using an NK Technologies' **Current Transducer** (AT Series) the resistance of the element can be determined and compared against a known ageing characteristic. When the element reaches a predetermined state it can be replaced prior to failure i.e. predictive maintenance. NK Technologies' **True RMS Current Transducers** (ATR Series) are used in conjunction with intelligent PLC systems when high power SCRs (also known as thyristors) or triacs are installed.

Insulation Breakdown

Industrial electrical heaters are prone to ground leakage due to the breakdown or contamination of insulators. The use of NK Technologies' **Ground Fault Sensors** enables early detection of leakage currents as small as 5mA. The on/off output of the sensor can be used to trigger a circuit interruption device (for example a shunt-trip breaker) or a monitoring device like a PLC to determine the required action. Latching and auto-reset models are available in both normally energized and normally de-energized configurations suitable for most applications.

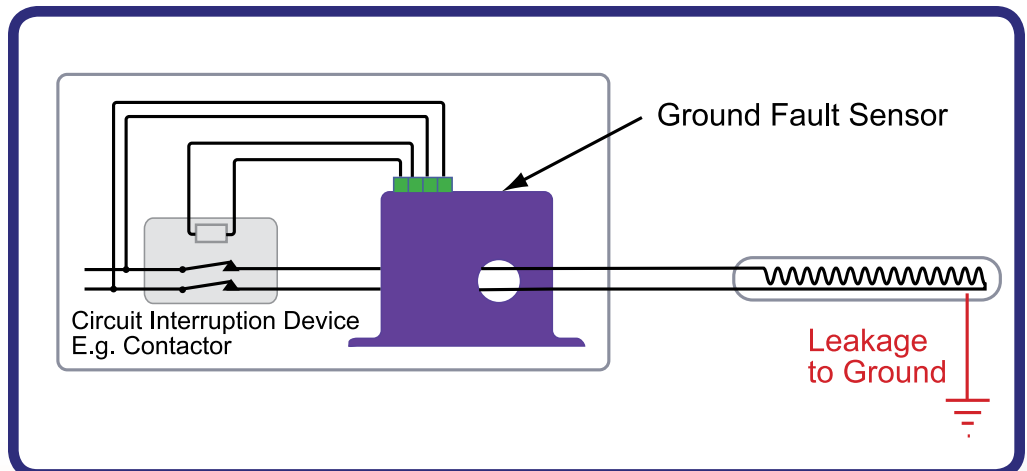

Ground Fault Monitoring on Heat Trace Systems



Heat trace cable is used to keep pipes or their contents from freezing, or to keep the contents at a constant temperature while being transferred from one location to another. The most common type of heat trace cable is the self-regulating type. Self-regulating cable contains two conductors and is usually physically attached to the pipe and is therefore is subject to mechanical damage. NK Technologies' **Ground Fault Sensor** (AG Series) are frequently installed to monitor heat trace circuits and systems. When a ground fault is detected, a circuit interruption device, like a contactor or shunt-trip circuit breaker, is used to automatically disconnect the faulty circuit. In many situations NEC and/or local electrical codes require the installation of ground fault interruption devices. However ground fault sensors are commonly installed, even if not required by code, in order to monitor the condition of the heat trace cable and installation and maintain safety. Faulty circuits can be identified and then repaired or replaced at a convenient time.

Snow Melt Systems

This application is similar to the Heat Trace System described previously, however there is a wider choice of generally lower-cost cable, which is often attached directly to roofs and gutters, or imbedded in sidewalks, steps, driveways or car parks. Although this type of installation is sometimes exempt from the code requiring ground fault protection, it is strongly recommended. The simple installation of an NK Technologies' **Ground Fault Sensor** will provide an early warning of trouble. Inevitably cable insulation deteriorates with age and stresses such as hydraulic action from ground water, resulting in current leakage to ground. This may create a hazardous situation for people or animals in contact with the installation; it will waste power and cause a significant drop in the heat output and the overall efficiency and thus effectiveness of the system. The circuit may continue to function, but snow and ice could continue to accumulate. If circuit interruption is required NK's **Ground Fault Sensor** should be installed in conjunction with a contactor, shunt trip breaker or other approved circuit interruption device.

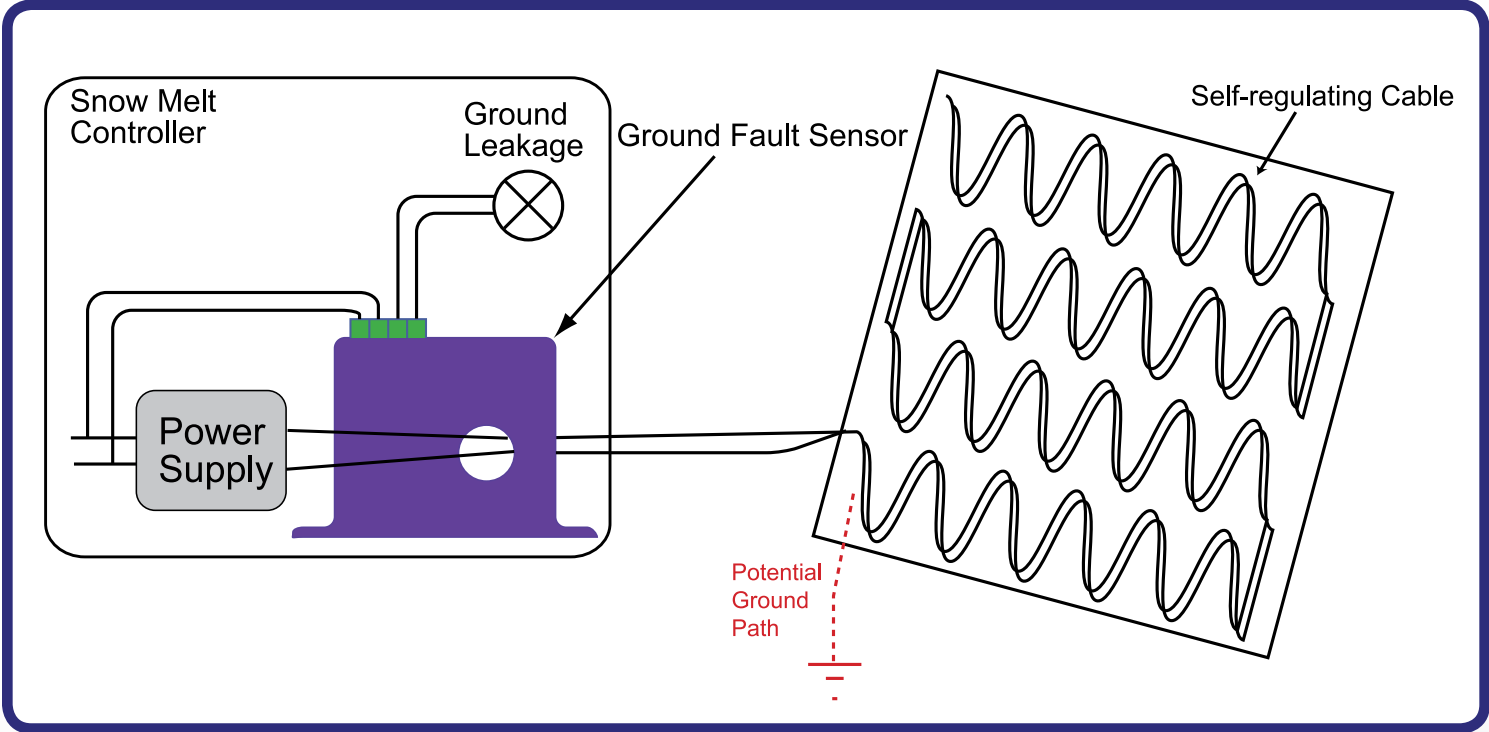

Industrial Lighting

Airports, tunnels, industrial complexes all require reliable lighting systems for safety. The measurement of current provides essential information regarding a lighting system either in conjunction with photo-sensors or on their own. Photo-sensors may be unreliable due to fogging and affects of ambient lighting. Current may be used for preventative maintenance on lamps with known life cycle characteristics.

Generally NK Technologies' Industrial Current sensors are used to sense current and provide signals to an intelligent control system like a Programmable Logic Controller (PLC) or a Lighting Controller. The following demonstrates just a few possible applications:



Lamp Failure Detection

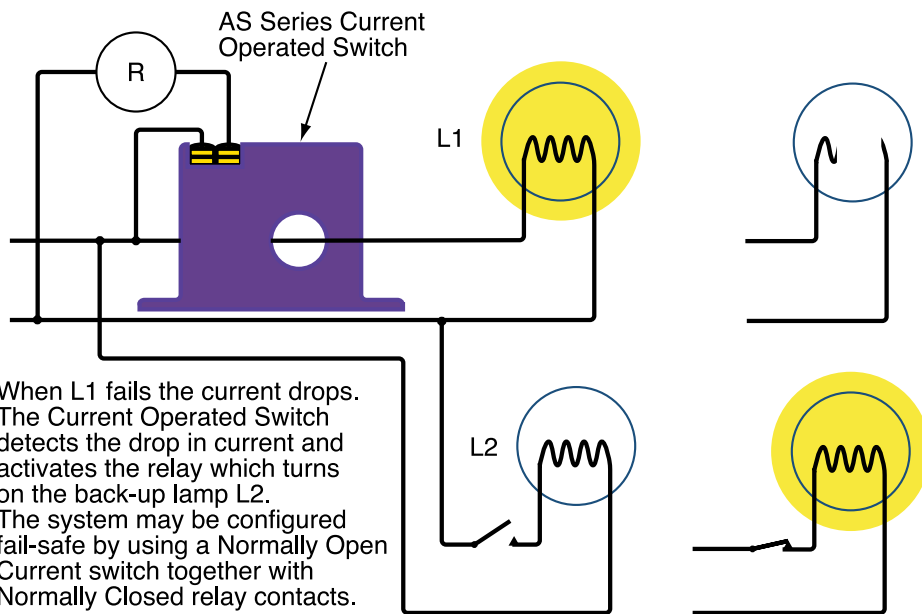

The simple addition of an NK Technologies' **Current Operated Switch** in a lighting circuit provides an isolated on/off signal to either a relay to automatically switch to a back-up lamp or signal a PLC to indicate lamp failure. The split-core model is designed for quick and simple installation for existing installations and the solid-core device provides a compact solution for new installations.

Preventative Maintenance of a Critical Lighting System

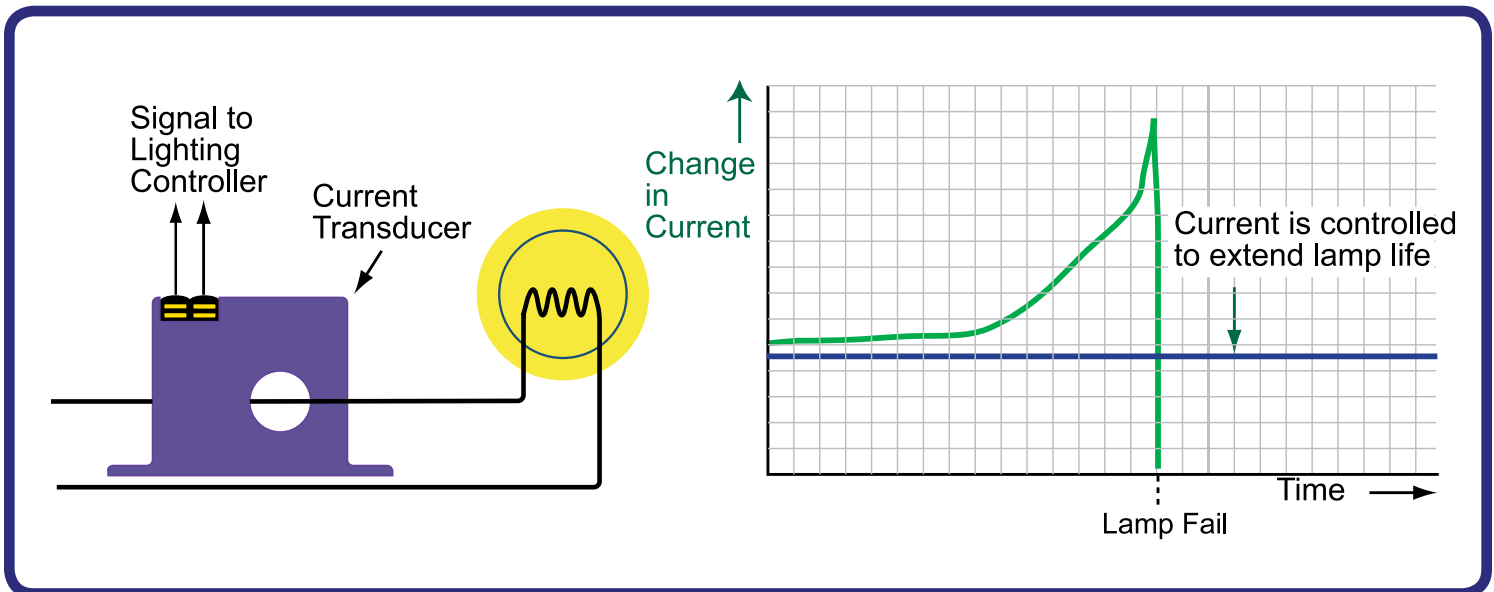

High technology lamps have been developed for a variety of specialized industrial and commercial applications. These lamps are expensive and their useful life should be maximized. Installing an NK Technologies' **Current Transducer** to measure the current draw of a lamp provides the information to determine the lamp's condition by comparison to known characteristics. Intelligent control devices, like PLCs, are programmed to adjust the applied voltage or current to optimize the life of the lamp.

UV & IR Lamp Status Monitoring

Ultraviolet (UV) lamps are used commonly to disinfect water by killing bacteria. High Intensity Infra Red (IR) lamps are used in a variety of industrial processes to provide heat both for drying and curing processes. Correct operation is very important and can be determined by measuring current draw. Using an NK Technologies' **Current Operated Switch** (AS1/3 series) provides simple and quick verification. The on/off contacts of the switch may be used to simply indicate status to an operator using a lamp or wired to the input of a PLC preprogrammed with the necessary corrective action. Alternatively, NK's **Current Transducers** (AT Series) may be used to provide an accurate measurement of the current draw by a UV, IR or other light source.

Miscellaneous

There are other electrical components and systems that use electric power where current measurement will provide useful and important information regarding status or provide protection.

Isolated Alarm System Interfacing

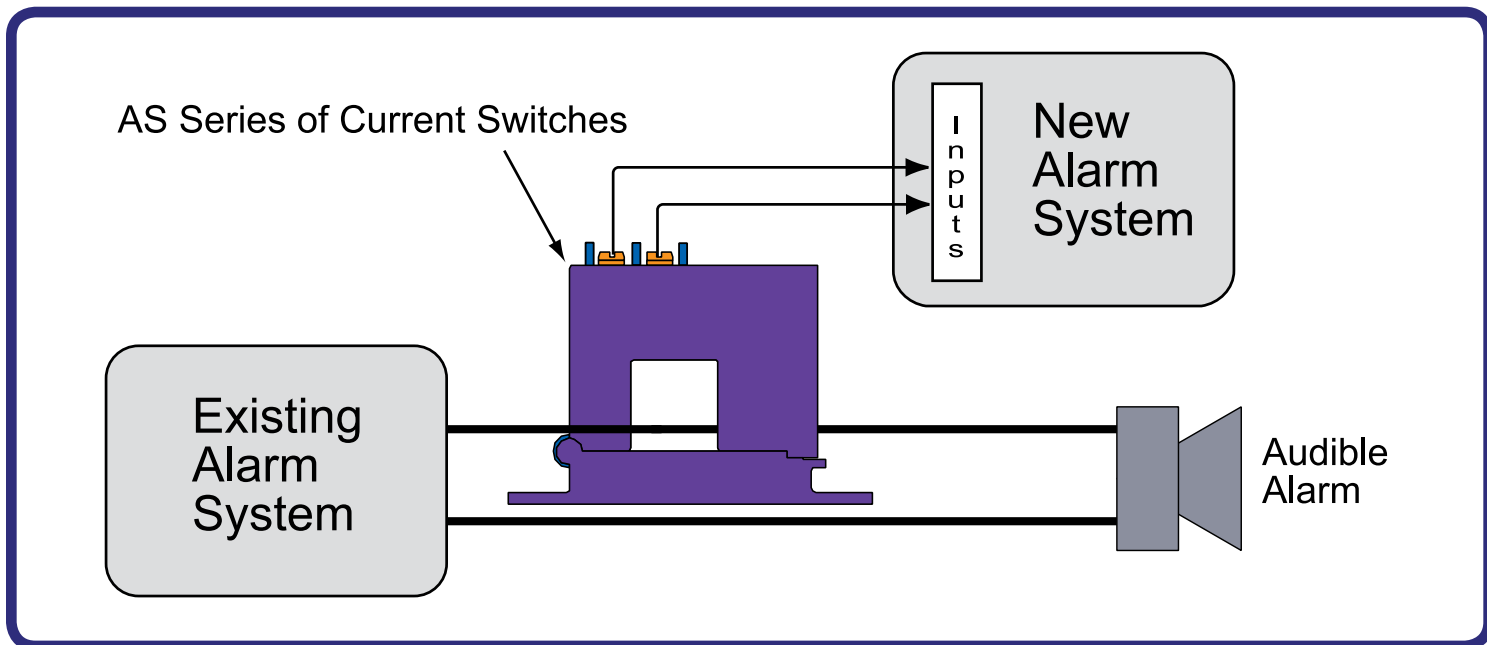

If an alarm or monitoring system is to be installed adjacent to another, (for example: a municipal hurricane or tornado warning system) it is desirable to tie in to it. This can be achieved by the utilization of an NK Technologies' **Current Operated Switch** (The split-core version is ideal for this). The switch simply detects current flowing in a conductor to say the audible or visual alarm providing a fully isolated 'repeater' signal. Switches are available for both AC and DC applications.

Battery Charging System

Industrial re-chargeable battery systems are used to provide primary power for vehicles and back-up systems for critical equipment, like cell phone base stations and other communications equipment. DC current flows in one direction during charging and in the opposite direction during battery operation. Traditional Current Transformers do not work with DC current and using current shunts has been the solution. The shunt operates by producing a voltage potential across its terminals according to Ohm's law. It suffers from a number of serious disadvantages:

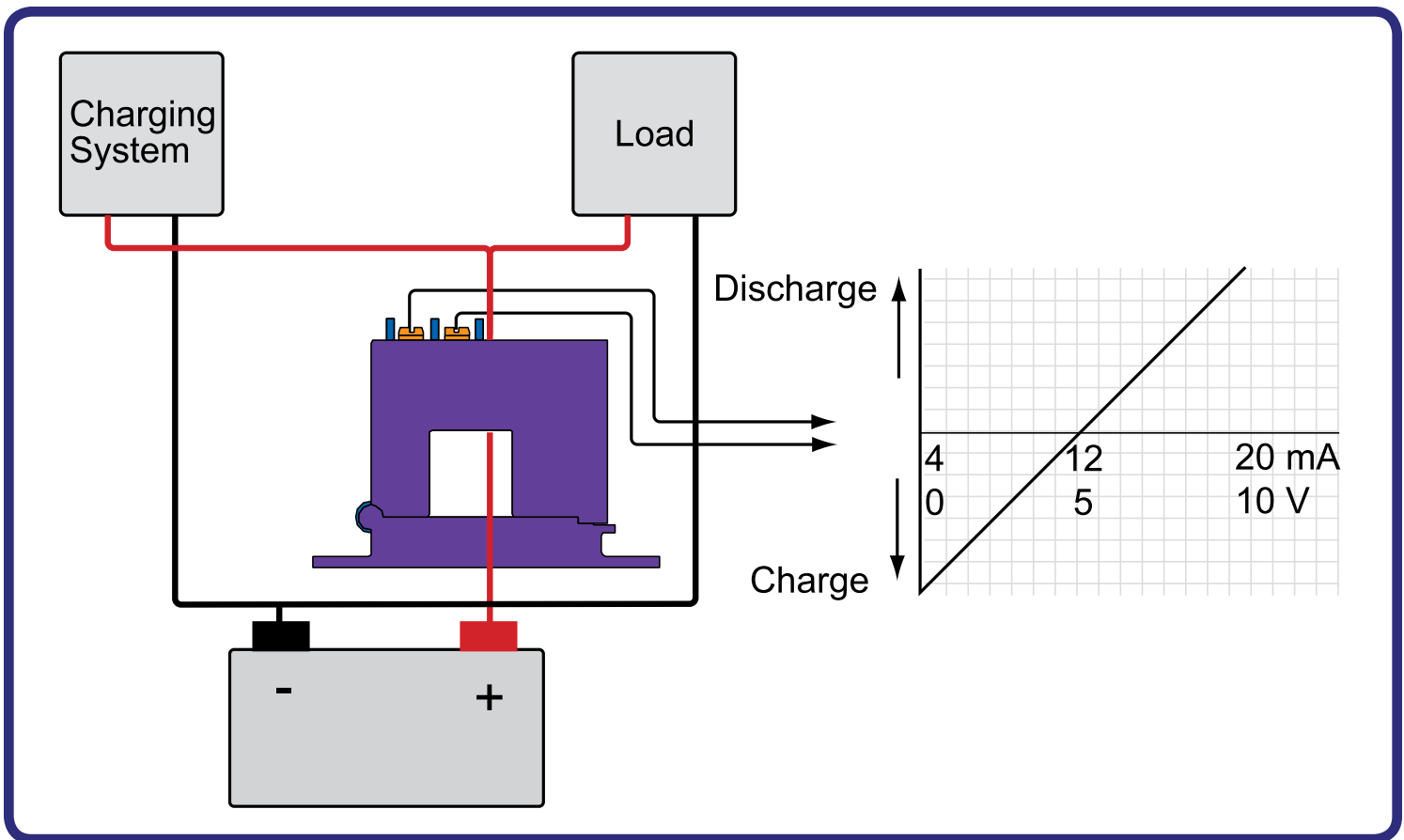

- Terminals can rise to the potential of the DC circuit
- The signal produced is usually 50-100mV at full rated current and must be isolated and amplified to a higher level signal (typically 4-20mA) to be of use to an industrial monitoring or control system.
- The shunt dissipates power according to the square of the current flowing through it. This manifests itself as a loss of power or an insertion loss.

Forget the shunt and instead simply pass the current carrying conductor through the aperture of an NK Technologies' **DC Current Transducer**. There is no insertion loss and the 4-20mA signal is fully isolated from both the DC current being measured and the power supply. The bipolar option also accommodates the change in direction of current flow.

Solar Panels



Photovoltaic arrays are used primarily in two ways to:

- Charge batteries that are used to power remote loads where installing a connection to the utility grid would be cost prohibitive
- Energize installations where the DC power is converted to 60 HZ AC power through a solid state inverter.

NK Technologies' **DC Current Transducers** can be installed so the output of the arrays can be monitored. These transducers are available in bipolar versions so that current may be measured during charging or discharging of the batteries.

Additionally NK Technologies' **Power Transducers** can be installed to monitor the voltage, current and frequency output from the inverter.

Current Transformer Monitoring

C.T.s (Current Transformers) have been used for many years to measure AC amperage. There are many C.T.s installed throughout Electric Utilities, Process Plants and Manufacturing facilities. Typically a C.T. provides either a 1 Amp, or more commonly a 5 Amp AC output on the secondary side. In order to use this signal for a modern control system (DCS, PLC or DDC) or Data Logging System a signal conversion or conditioner device is required to provide an analog DC signal. C.T.s step down current and the secondary has to feed into a very low impedance to maintain

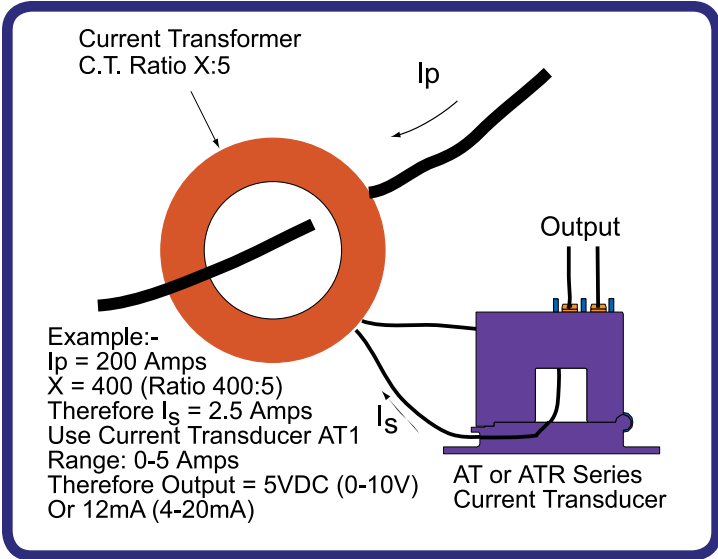

accuracy. In the event that the secondary is open-circuited during operation the device operates as a step-up voltage transformer since there is nowhere for the current to flow and voltages of several kV appear on the secondary, overheating occurs and combustion or explosion often results. NK Technologies' Split-Core **Current Transducers** are simply and safely snapped over the shorted secondary of a C.T. to provide a fully isolated analog 4-20mA DC signal proportional to the current in the secondary, which in turn is proportional to the measured (primary) current.

NK's Split-core Current transducers are used to safely monitor the secondary of high voltage C.T.s used in power generation and distribution in the low voltage cubicles.

Equipment Ground Fault Monitoring

As we become more aware of occupational health and safety so the need for protection against ground faults is growing. Industrial electrical equipment is fed via a distribution system which in turn is connected to a main feed. Ground fault protection may be installed, for instance at a main breaker, protecting the branch circuit but not necessarily a valuable or critical piece of equipment. Industrial **Ground Fault**

Sensors from NK Technologies are designed to be installed in individual pieces of equipment or their electrical feed. The sensors provide an on/off output that may be used to operate a circuit interruption device like a shunt trip breaker or feed into an alarm system. With over 100 models to choose from, there's sure to be one to fit your application.

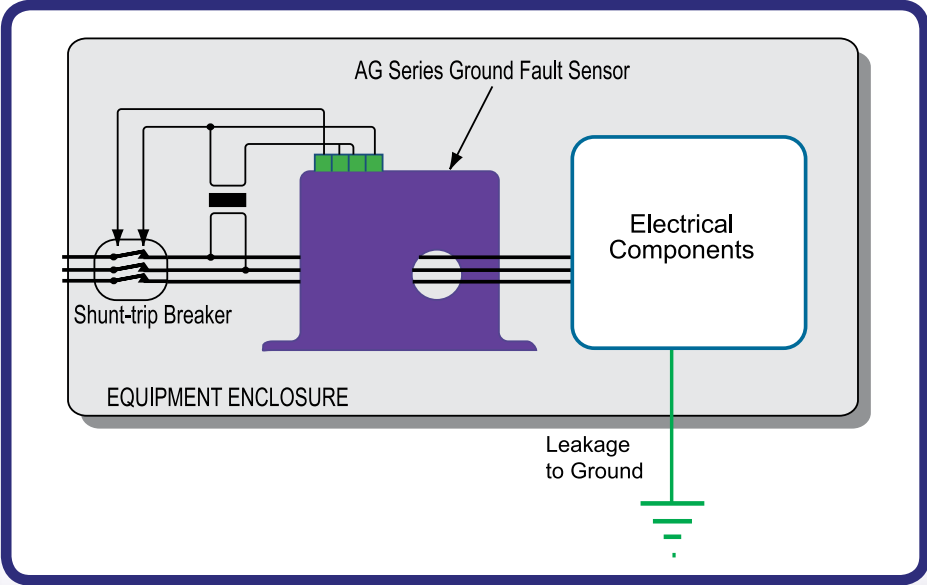

Generator Installations

The need for back-up power for critical loads is becoming more and more apparent to operating and maintenance personnel. Many existing factories and facilities are also adding generators to assist the grid connection supply during times of excessive consumption, or to help the plant ride through periods of peak usage when the utility charges a premium for power. Monitoring the current demand provided from a generator allows for load shedding of non-critical loads when the generator is nearing its capacity. NK Technologies' **Current Operated Switches** close when the demand, measured by current, is too high, and by connecting to a controller (like a PLC), less critical loads can be disconnected from the system.



Power Transformer Monitoring



Installing an NK Technologies' **Current Transducer** over the conductors on the secondary of a transformer can be used to alarm if the current draw reaches a critical level. Action can then be taken to reduce the load before the transformer overheats.

Most large power transformers utilize auxiliary cooling fans, drawing cooler air from a distance away from the transformer. NK Technologies' **Current Transducers** or **Current Operated Switches** are used to monitor these fans for overload from bearing failure, under loads from drive component breakage or slippage, and to just be sure that the fan is energized and doing its required job.

Power Factor Correction Control

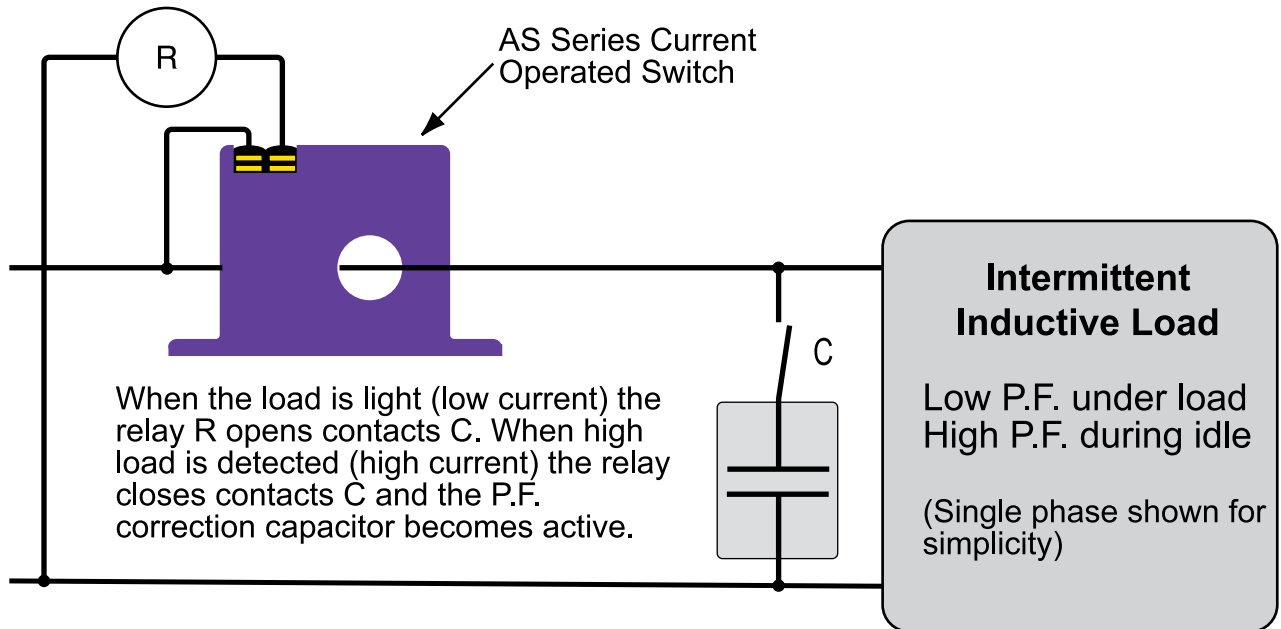

With ever increasing demands for electrical power the power generating companies are beginning to penalize customers with low Power Factors. Low PFs can be considered very inefficient use of electrical energy. A low PF can be corrected by the installation of PF Correction capacitors. Although this can be achieved at the main feeder most facilities, due to multiple varying loads, choose to install PF correction on individual pieces of equipment (like a large motor) or area of plant. When a load is switched off, unless the PF correction capacitors are removed, undesirable over-correction occurs. Sophisticated automatic control systems are available but are very expensive. A simple way to switch a PF correction capacitor bank is to use an NK Technologies' **Current Operated Switch**. When the load goes down, for example at night when equipment is not used, the PF correction capacitor is switched out. Then when load returns it is switched back in.

Miscellaneous

Welder Tip Dressing



Motor-driven tip dressers are used in conjunction with robotic resistance welders in a manufacturing area like an automobile body assembly plant. Essentially they are like large pencil sharpeners and they require regular maintenance. After maintenance the dressers are not always switched back on, so that when the robotic welder requests tip sharpening, the tips are not dressed and poor quality welds result, which in turn produces poor quality panels. By installing an NK Technologies' **Current Operated Switch** on the tip dresser the status is signaled and an alarm is generated to warn if the dresser remains un-powered and offline. NK's unique split-core packaging is ideal for retrofit installation and the compact solid-core unit is well suited for OEM applications.

Safety Interlocks

NK Technologies' **Current Operated Switches** are available in models that will switch at measured currents from just a few milliamps (mA) to over 100 amps. Detecting current flow is the definitive measurement to determine if equipment is on or off, a motor is running or not, a heater is on or off etc. NK's Current Switch products are installed for interlocking for operational and safety purposes.

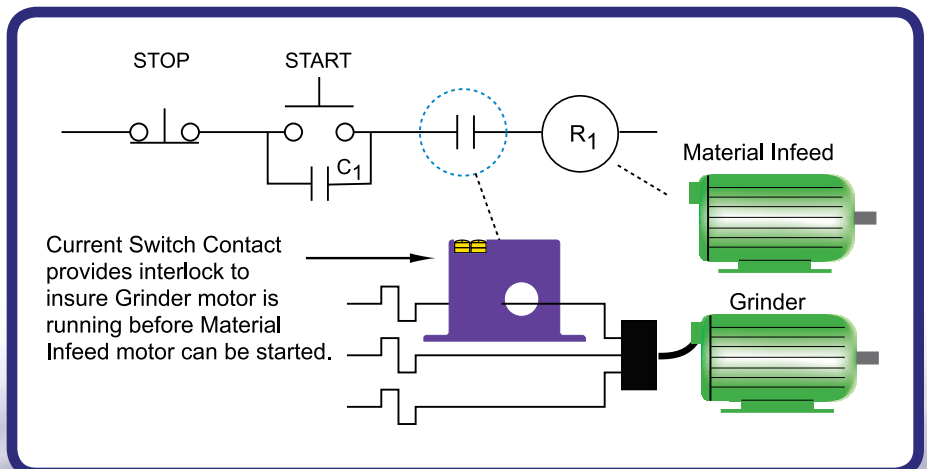

Drill/Tool Status

Automated drilling machines usually provide fast and accurate holes, that is until the drill bit breaks. The last thing a high production furniture manufacturer wanted to do is to keep drilling parts with one hole missing! NK Technologies' **Current Operated Switches** were installed over the current carrying conductor feeding the drill motor and when the amperage dropped below a preset level a signal was sent to the controller to stop operation so that the drill bit could be changed. NK's range of current transducers are used in a variety of applications on machine tools to detect status.





DO YOU HAVE OTHER NEEDS?

Contact Us For:

- Current Transducers and Transmitters
- Current Operated Switches
- Ground Fault Sensors
- Power Transducers, CTs and PTs
- Voltage Transducers

*For expert technical help, contact your local
Authorized Representative or Authorized Distributor*